

Model 975XLHBM

Hydrant Backflow Meter



□ Installation □ Testing □ Maintenance Instructions

CAUTION: Installation of Backflow Preventers must be performed by qualified, licensed personnel. The installer should be sure the proper device has been selected for the particular installation. Faulty installation could result in an improperly functioning device.

The ZURN WILKINS Model 975XLHBM Hydrant Backflow Meter consists of a ZURN WILKINS 2" Model 975XL Reduced Pressure Principle Backflow Preventer and a 3" water meter for use on water lines where usage must be metered and a health hazard could exist if a backflow situation were to occur.

Proper performance is dependent upon following these installation instructions and prevailing governmental and industry standards and codes. Failure to do so, according to ZURN WILKINS Limited Warranty "...releases ZURN WILKINS of any liability that it might otherwise have with respect to that device." Such failure could also result in an improperly functioning device.

Damage to the device could result wherever water hammer and/or water thermal expansion could create excessive line pressure. Where this could occur, shock arresters and/or pressure relief valves should be installed downstream of the device.

1. Before installing a Model 975XLHBM, flush the line thoroughly to remove all debris, chips and other foreign matter. If required, a strainer should be placed upstream of the Backflow Preventer.

CAUTION: Do not use a strainer in seldom used emergency waterlines such as fire lines.

2. The Model 975XLHBM must be installed in a horizontal position to provide proper operation of the relief valve.
3. Provide adequate space around the installed unit so that the test cocks will be accessible for testing and servicing.
4. If installation of a Model 975XLHBM is in a building, provide a suitable drain arrangement to drain off spillage from the relief valve. An air gap at least two times the pipe diameter must be provided between the relief valve and the drain piping to prevent a cross-connection.

CAUTION: Do not pipe the relief valve solidly to a floor drain, sewer or sump.

5. Install valve at least 12 inches above surrounding flood level.
6. Always consult local codes for installation methods, approvals and guidance.

OUTDOOR INSTALLATION

ZURN WILKINS Model 975XLHBM Backflow Preventers may be installed outdoors only if the device is protected against freezing conditions. Exposure to freezing conditions will result in improper function or damage to the device. The installation location must be kept above 32°F. All the basic installation instructions apply.

If installation is in a pit or vault, the 975XLHBM must never be submerged in water because this could cause a cross-connection. Make sure that the pit or vault always remains dry by providing ample drainage.

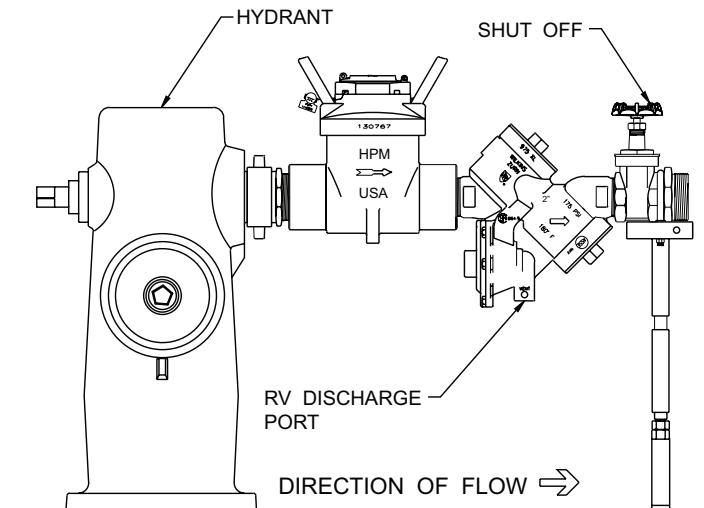

**TYPICAL INSTALLATION
ZURN WILKINS 975XLHBM
Hydrant Backflow Meter**

PLACING THE DEVICE IN SERVICE

After the installation of a Model 975XLHBM has been completed, place the unit in service as follows:

1. Start with hydrant and shut-off valve closed. Slowly open the hydrant until the backflow preventer is completely pressurized. A brief discharge from the relief valve may occur while the device is pressurizing. The discharge should cease by the time the hydrant is fully open. If the discharge does not stop, refer to "MAINTENANCE INSTRUCTIONS" for repair procedures.
2. After the device has been pressurized, vent all trapped air from both check valves by slightly opening each of the four test cocks.
3. Slowly open the downstream shut-off valve. The Model 975XLHBM is now in service.
4. If "spitting" or intermittent discharges from the relief valve are noted, it could be a result of pressure fluctuation and/or a water hammer condition in the system. If such conditions exist, install water pressure reducing valves or water hammer shock arresters in compliance with industry standards as needed.
5. After the Model 975XLHBM has been properly installed, test the device (see "TEST PROCEDURES"). If the device fails the test, remove the first and second check valves and thoroughly flush the device. If the relief valve fails to operate properly, inspect the sensing passage for clogging (see "MAINTENANCE INSTRUCTIONS"). Clean rubber seals of all debris and place unit back in service.

Proposition 65 Warning This product contains chemicals known to the State of California to cause cancer or birth defects or other reproductive harm.

In accordance with U.S. Federal Safe Drinking Water Act Lead-Free requirements, as of January 4, 2014, this product can only be used in water systems considered non-potable. Please contact your local water utility for further requirements.

Testing Procedures

MODEL 975XLHBM HYDRANT BACKFLOW METER ASSEMBLY

Equipment Required: Differential pressure gauge test kit.

975XLHBM TEST NO. 1

Purpose:

Test #2 check valve for tightness against reverse flow.

Requirement:

The valve must close tight against reverse flow under all pressure differentials.

Procedure:

1. Attach the "HIGH" hose to test cock #1 and the "LOW" hose to test cock #2.
2. Close shut-off valve.
3. Open test cocks #1 and #2.
4. Open by-pass valves "C" and "A" and bleed to atmosphere until all air is expelled.
5. Close by-pass valve "A". Open by-pass valve "B" and bleed to atmosphere until all air is expelled. Close by-pass valves "B" and "C".
6. Attach the "VENT" hose to test cock #3.
7. Slowly open by-pass valves "A" and "C" and keep by-pass valve "B" closed.
8. Open test cock #3.
9. Indicated pressure differential will drop slightly. If pressure differential does not continue to decrease, the #2 check valve is considered tight.

975XLHBM TEST NO. 2

Purpose:

Test #1 check valve for tightness and record pressure drop across #1 check valve.

Requirement:

The static pressure drop across #1 check valve shall be greater than the relief valve opening point (test #3), and at least 5.0 psid.

Procedure:

1. Close by-pass valve "A"
2. Close test cock #3, and disconnect "VENT" hose from test cock #3.
3. Open by-pass valves "B" and "C" bleeding to atmosphere, then close by-pass valve "B" restoring the system to normal static condition.
4. Observe the pressure differential gauge and note this as the #1 check valve psid.

975XLHBM TEST NO. 3

Purpose:

To test operation of the differential relief valve.

Requirement:

The pressure differential relief valve must operate to maintain the "ZONE" between the two check valves at least 2 PSID less than the supply pressure.

Procedure:

1. Close by-pass valve "C" and open by-pass valve "A".
2. Open by-pass valve "B" very slowly until differential gauge needle starts to drop. Hold the valve at this position and observe the gauge reading at the moment the first discharge is noted from the relief valve. Record this as the opening differential pressure of the relief valve.

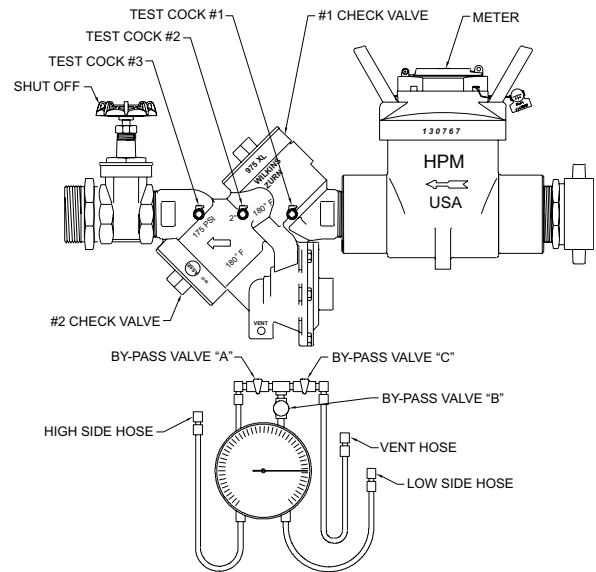

Maintenance Instructions

All Model 975XLHBM Hydrant Backflow Meters must be inspected and maintained by licensed personnel at least once a year or more frequently as specified by local codes. Replacement of worn or damaged parts must only be made with genuine "ZURN WILKINS" parts. The ZURN WILKINS Certificate of Limited Warranty provides that failure to do so "...releases ZURN WILKINS of any liability that it might otherwise have with respect to that device." Such failure could also result in an improperly functioning device.

The Model 975XLHBM Hydrant Backflow Meter should be thoroughly flushed after backflow conditions occur to prevent any type of corrosive deterioration to its components. Failure to do so could result in malfunction of the device.

GENERAL MAINTENANCE

1. Clean all parts thoroughly with water after disassembly.
2. Carefully inspect rubber seal rings, diaphragms and o-rings for damage.
3. Test unit after reassembly for proper operation (see "Testing Procedures").

SERVICING CHECK VALVES

1. Close inlet and outlet shut-off valves.
2. Open No. 1, No. 2 and No. 3 test cocks to release pressure from valve.
3. Unscrew check valve covers using appropriate size wrench (**CAUTION:** Cover is spring loaded). To avoid injury, hold cover down firmly with one hand while unscrewing.
4. Remove check valve cover, spring and poppet assembly.
5. Inspect the rubber seal ring for cuts or embedded debris. To remove seal ring, remove screw and seal ring retainer. If the reverse side of the seal ring is unused, it is possible to invert the seal ring. This would be considered a temporary solution to fixing a fouled check and should be replaced with a new seal ring as soon as possible.
6. Inspect valve cavity and seating area. Remove any debris.
7. If installed with removable seat, unscrew seat from body and replace with new seat and lightly grease o-ring*
8. Reverse the above procedures to reinstall check valve assembly. Care should be taken to make sure the heavy spring is installed in the No.1 check valve (Model 975's series only).

Maintenance Instructions

SERVICING RELIEF VALVE

1. Remove relief valve cover bolts and cover. Gently pull on diaphragm to remove the cartridge assembly.
2. Inspect seal ring for cuts and embedded debris. Turn over or replace if required.
3. Disassemble cartridge by unscrewing relief valve retaining screw.
4. Inspect diaphragm and o-rings for damage. Replace required parts and apply a light coat of grease to plunger o-ring.
5. Carefully reassemble cartridge assembly.
6. Inspect relief valve seat for wear on seating surface. If damaged, replace seat and seat o-ring.*
7. Insert cartridge assembly into relief valve body.
8. Replace relief valve cover and cover bolts.
9. Place device in service and test per "TESTING PROCEDURES"

*For seat removal assistance, consult factory.

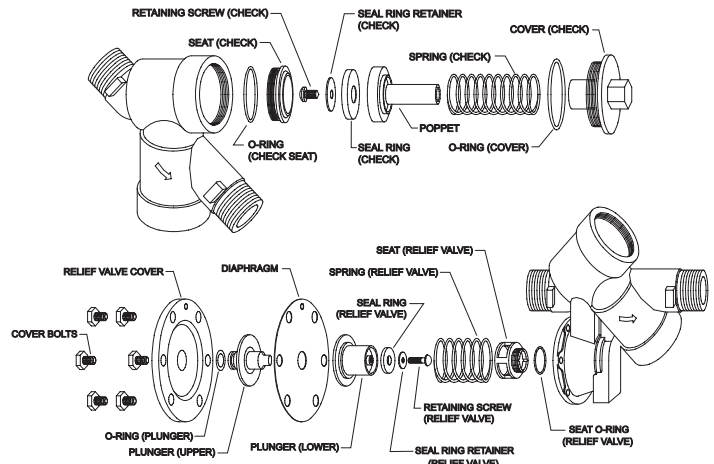

Troubleshooting

When the relief valve discharges intermittently it can be almost always assumed that the device is functioning correctly and that the discharge is caused by systems problem such as inlet pressure fluctuations or water hammer due to quick closing valves.

<u>PROBLEM</u>	<u>POSSIBLE CAUSES</u>	<u>CORRECTIVE ACTION</u>
1. SUDDEN OR RAPID SPITTING	<ol style="list-style-type: none"> 1. Drop in inlet pressure. 2. Sudden increase in downstream pressure due to water hammer from quick closing shut-off valve installed downstream. 	<ol style="list-style-type: none"> A. Install an in-line spring loaded check valve upstream of back flow. B. Install pressure reducing valve up stream of backflow unit. C. Install in-line spring loaded check valve downstream of backflow as close to source as possible, but not closer than 4 feet.
2. LIGHT INTERMITTENT DRIP	<ol style="list-style-type: none"> 1. Slightly fouled #1 check 	<ol style="list-style-type: none"> A. Clean #1 check and turn check valve seal ring over or replace.

Continuous discharge of the relief valve signifies a failure of some part of the device. To help determine the specific area of failure, close the #2 shut-off valve. If the discharge stops, the #2 check requires service. If the discharge continues, the #1 check requires service.

1. CONTINUOUS DISCHARGE	<ol style="list-style-type: none"> 1. Fouled #1 check. 2. Fouled relief valve seat. 3. Fouled #2 check. 	<ol style="list-style-type: none"> A. Clean check valves and turn check valve seal rings over or replace. B. Clean relief valve seat and turn relief valve seal ring over or replace.
--------------------------------	--	---

In summation, the amount of discharge is proportional to degree of fouling. Most problems occur in the #1 check which is where debris enters the backflow preventer first.

FLOW CHARACTERISTICS

MODEL 975XLHBM, 2" (STANDARD & METRIC)

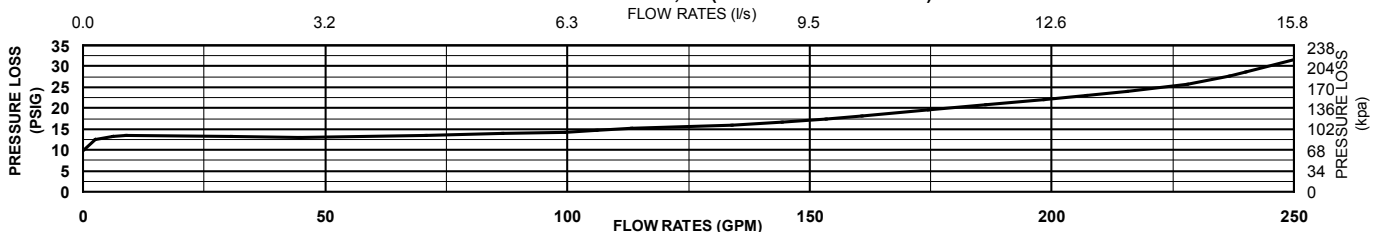

Replacement Parts

ITEM	DESCRIPTION	WILKINS P/N
1A	Screw Skt Cap SS M5-0.8 x 16	HBM-11A
1B	Screw Skt Cap SS m5-0.8 x 16, Drill Hole	HBM-11B
2	Washer lock Wave CU M5 x 10	HBM-14A
3	Cover Retaining Ring and Lid, Brass	HBM-20
4-US	Register, 3" Turbine, U.S. Gallon	HBM-1CFM
4-CF	Register, 3" Turbine, Cubic Feet	HBM-1CMM
4-CM	Register, 3" Turbine, Cubic Meters	HBM-1
5	Magnet Barrier Ring	HBM-26
6A	Bolt Hex Cap SS 1/2-13 x 1.5	HBM-11C
6B	Bolt Hex Cap SS 1/2-13 x 1.5, drilled hole	HBM-11D
7	Washer Flat SS .515 ID x .875 OD	HBM-14B
8	FHM Double Handle, SS	HBM-6
9	Screw Slot Pan SS M5-0.8 x 28	HBM-11E
10	FHM Flat Al Cvr Pit, Coat Wilkins Blue	HBM-3C

ITEM	DESCRIPTION	WILKINS P/N
11	Turbine Meter. Measuring Element, 3"	HBM-25
12	O-Ring for Measuring Element	HBM-22A
13	FHD Meter. Body, Pwdr. Coat Wilkins Blue	HBM-20D
14	Swivel, 2.5" SW x 2.5"MIP, Brass	HBM-19C
15	Perf. Hydrant Stand	HBM-55
16	Nipple 2.5"NH x 2"MIP, Brass	956-19BFDC
17	Gate Valve, 2" NRS Brass	2-48BR
18	2" 975LXL	2-975LXL
19-US	HBM Water Mtr. w/inlet Tailpiece, U.S. Gallons	556-54
19-CF	HBM Water Mtr. w/inlet Tailpiece, Cubic Feet	556-54CFM
19-CM	HBM Water Mtr. w/ Inlet Tailpiece, Cubic Mtrs.	556-54CMM

MISC	Complete FHD Unitized Measuring Element Assembly items 1-5 & 9-12 listed above. **=US, CF or CM	HBM-2ME HBM-2MECFM HBM-2MECMM
------	---	-------------------------------------

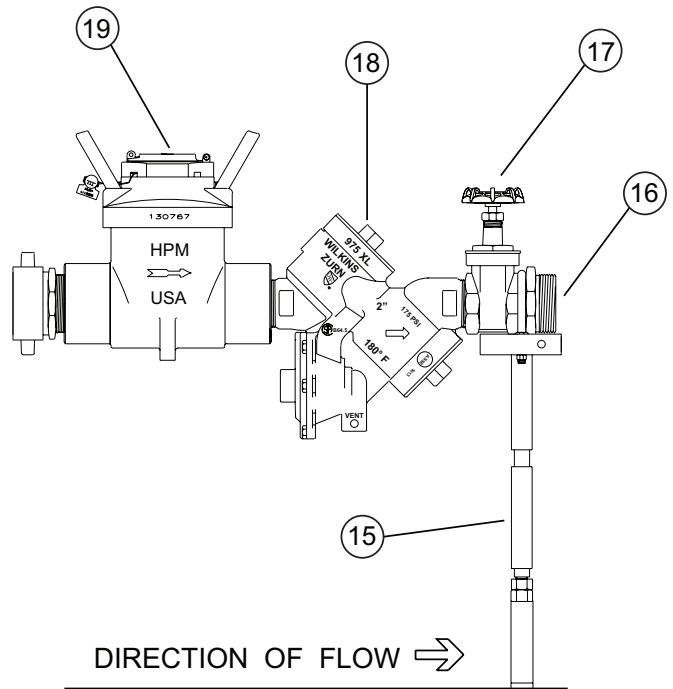
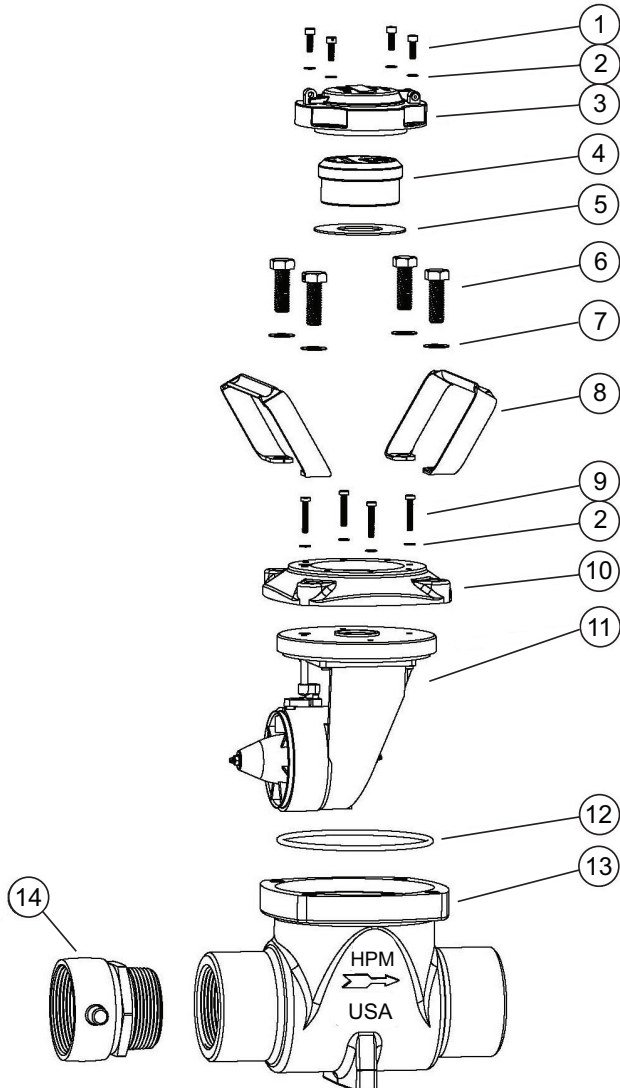

Proper performance is dependent upon licensed, qualified personnel performing regular, periodic testing according to ZURN WILKINS' specifications and prevailing governmental & industry standards and codes and upon following these installation instructions. Failure to do so releases ZURN WILKINS of any liability that it might otherwise have with respect to that device. Such failure could also result in an improperly functioning device.